

## Dolly axle in fixed design

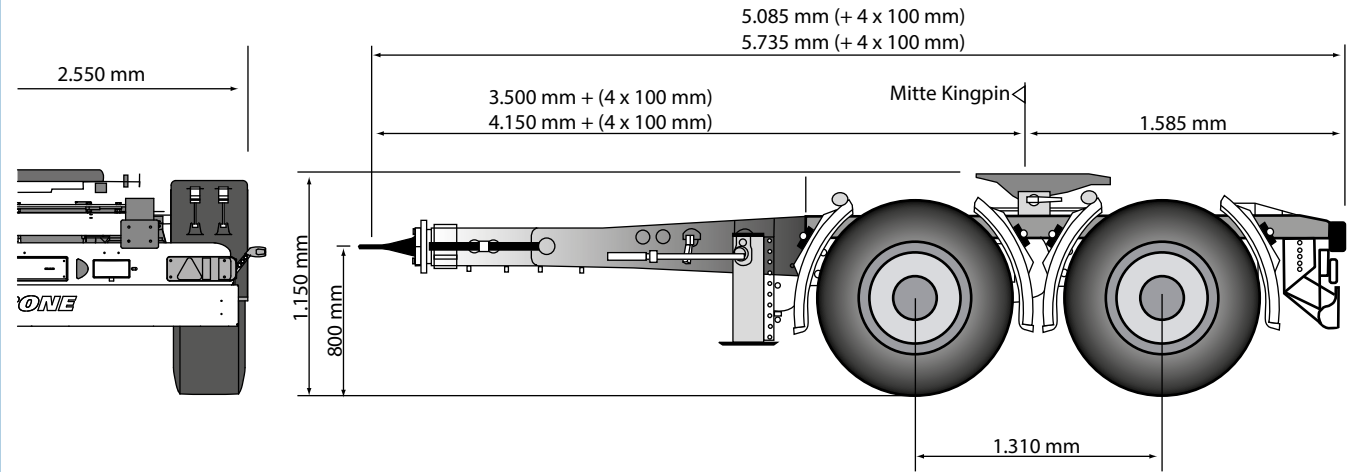

## 3-D-View

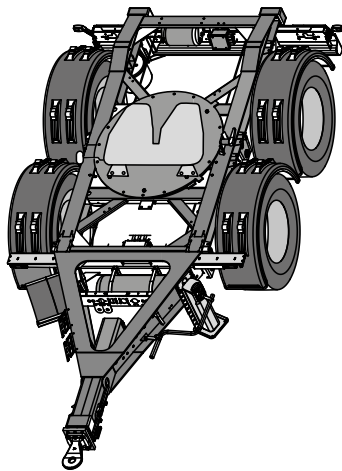

## Technical description

- Double T-longitudinal beams with cross members in welded construction
- Cast iron fifth wheel, height: approx. 170 mm, mounted on rotating assembly
- Rear bumper according to EC-regulation
- Draw bar with bolted 50 mm or 57,7 mm towing eye, length: 4,150 mm (+ 4 x 100 mm (low coupling) or length 3.500 + 4 x 100 mm (high coupling), middle towing eye to middle fifth wheel
- Front support with crank and gear
- Low-maintenance axles with air suspension and disc brakes (430 mm), ET 120; ; raise/lower valve (1 valve); Rims centre nave
- Tyres: 4 x 385/55 R 22.5, brand: Krone choice
- Wheel covering according and spray suppression according to EC-regulations; natural black wheel covering, quarter shell, with a top cover, mud flaps at rear
- Brake system according to ECE R 13, including vehicle stabilising system; spring parking brake; 2S/2M EBS system, 2 sensors on one axle with RSS, diagnostics by ISO 7638 socket (EBS); brake connection for trailer on guide rail; Palm coupling for air system (Trailer)
- Lights according to UN ECE reg. no. 48; 24 volts lighting system with 2 x 7-pin socket DIN ISO 1185/3731; front and rear marker lights; two multi-function rear lights incl. rear fog light and reversing lights; contouring lights, number plate lights and side marker lights in LED; Electrical connection for Trailer mounted on guide rail; Connecting cable for electric- and air connection (Trailer)
- Steel parts shot blasted, with KTL primer and high-quality surface coating (standard painting single-colour); axles incl. wheel hubs painted black; underrun protection and light panel powder coated white for safety reasons; wheels silver with high-quality paint finish; reflective outline marking according to ECE-R48

## Technical data

Type:	ZZB 18 eL
Allowable gross weight:	18,000 kg
Dolly-King pin load:	16,000 kg
Tare weight, approx.:	2,600 kg
5th wheel height, approx.:	990 - 1,170 mm
Coupling height (unloaded), approx.:	400 - 700 mm
Axle spread	1,310 mm
Total length (basic position)	5,085 / 5,735 mm

(Dimensions and weights for standard units)